

DIAMOND BURNISHING TOOLS

Features :

- ◆ High Quality Mirror Finish is achieved
- ◆ Suitable for any Straight OD
- ◆ Used on Traditional & CNC Lathes.
- ◆ Replaceable Diamond Stem.



Mech-India Diamond Burnishing Tools completed with a selected diamond stem are suitable for carrying out the burnishing of turned or ground surfaces on many of metals for achieving high level finishing i.e. 0.05 to 0.20 μ Ra. It is possible to burnish cast iron to get surface finish 0.2/0.4 μ Ra.

The Diamond Burnishing Tools are compact and with shank of 20 or 25 mm square. Thus the ideal tool is also used on small lathes.

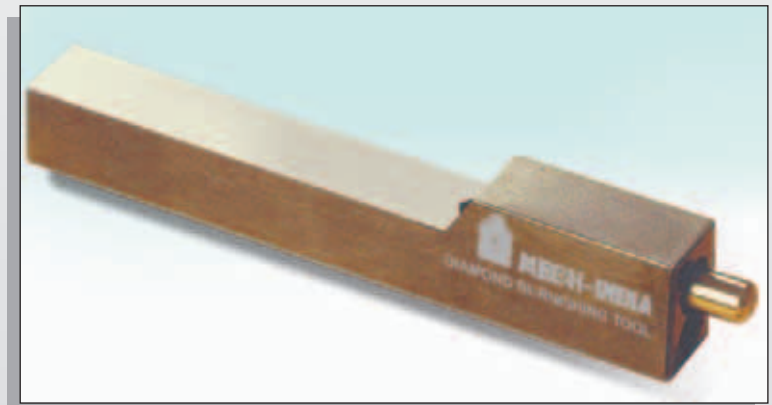

The Diamond Burnishing Tools can be used on traditional or CNC lathes. After having installed the tool on the tool-post, so that the diamond gets in touch on the middle of the part, obtaining an angle of 90° with respect to the surface to burnish. After the tool gets in touch with the surface to be burnished, put the spring under pressure. The feed should be 0.07 / 0.1 mm per revolution & the speed same as turning speed.

The tools have a precision diamond stem mounted on the top. It is possible to burnish materials with a hardness upto 40 HRc, obtaining a finishing of 0.04 / 0.15 μ Ra.

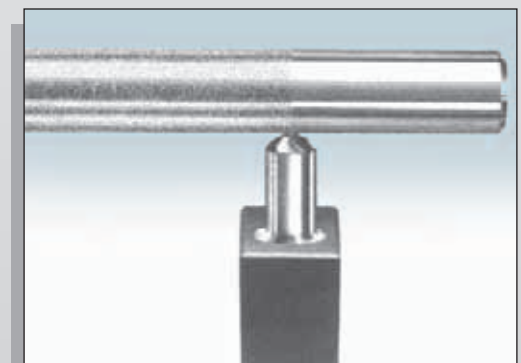

DIAMOND BURNISHING TOOLS

Construction & Specifications

The tool is suitable for the burnishing of linear surfaces. With this tool it is possible to carry out a burnishing upto a distance of 6 mm from the shoulder.

Model no. DB200

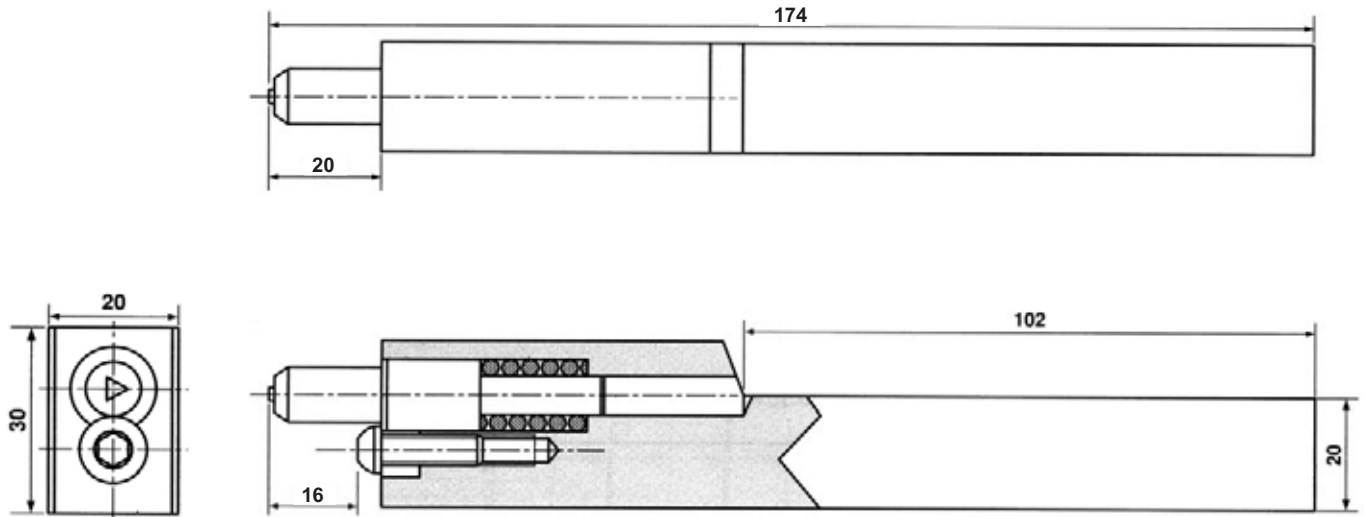

DIAMOND BURNISHING TOOL MODEL DB200

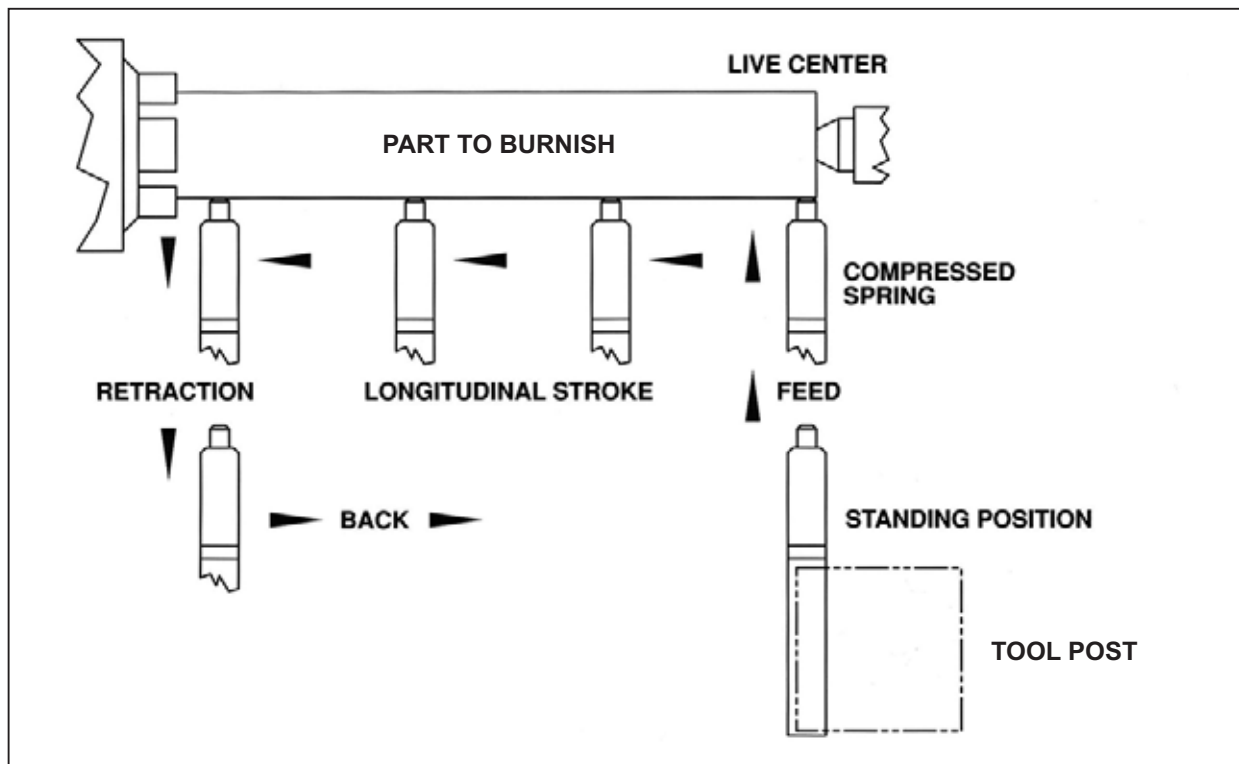

MECH-INDIA ENGINEERS PVT. LTD.

103, Godavari, Laxmi Indl. Complex, Vartak Nagar, Thane : 400 606 (Mumbai), India.
Tel. : 022-2585 3293 • Fax : + 91-22-2588 6249.

E-mail : sales@mechindia.com • Web : www.mechindia.com

